

Features

- Ranges: 1.5 psi (100 mbar) through 10,000 psi (700 bar) gauge or absolute
- Accuracy: $\pm 0.08\%$ full scale (FS), best fit straight line (BSL)
- Stability: 0.1% FS per year
- Thermal effects: 0.005%/°F ($\pm 0.009\%/^{\circ}\text{C}$)
- Reliability: MTBF of 100 years
- NACE compatible
- High proof and containment pressures
- Certified intrinsically safe
- RFI protected

The PTX 651 and PTX 671 process transmitters combine micromachined silicon sensor technology with a fully welded stainless steel/Hastelloy construction to provide a high accuracy, stable, rugged pressure transmitter. These materials and environmental protection are ideal for arduous applications such as offshore and petrochemical.

By incorporating technology developed for demanding aerospace and military applications, the PTX 651/PTX 671 provide excellent long term stability and feature minimal output noise, non-linearity and hysteresis.

Process connections have been standardized as 1/2 NPT with a choice of electrical connections, either 3/4 NPT female conduit or junction box.

Each transmitter incorporates RFI/EMC spike protection and is certified intrinsically safe.

Within the junction box is a quick disconnect feature which negates the need to remove heavy duty cables when changing transmitters.

PTX 651/671

Druck Offshore/Process Pressure Transducers

PTX 651/671 is a Druck product.
Druck has joined other GE
high-technology sensing
businesses under a new
name—GE Industrial, Sensing.



PTX 671

PTX 651

PTX 651/671 Specifications

Standard

Operating Pressure Range

Any pressure unit and (zero based) span available between 5 psi (350 mbar) and 10000 psi (700 bar) FS to gauge and absolute formats: spans down to 1.5 psi (100 mbar) available in gauge format only.

Overpressure

2 x FS minimum

Proof Pressure

1.5 x FS minimum

Transmitter Supply Voltage

9 to 30 VDC

This voltage must occur across the transmitter terminals.

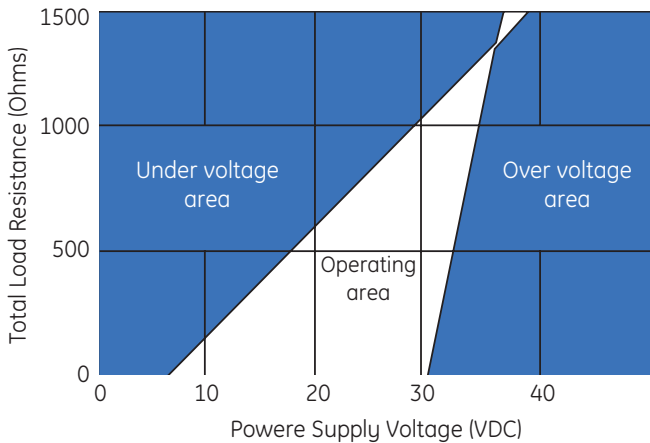

Output Current

4 to 20 mA (two-wire configuration) proportional for zero to FS pressure.

Enclosure Sealing

Type 4X/IP66

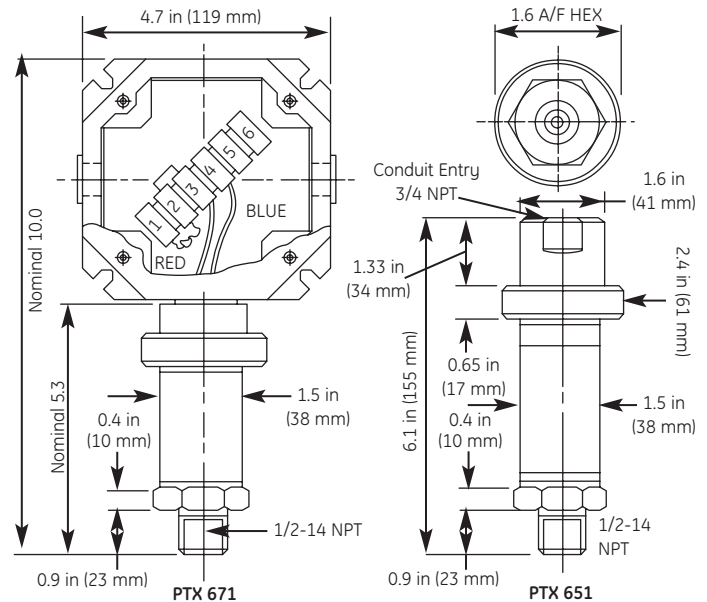

PTX 651/671 installation dimensions

Combined Non-linearity, Hysteresis and Repeatability

Terminal definition

The output will not deviate from the straight line connecting zero and FS output by more than 0.15% FS (Typically 0.1% FS).

Best fit straight line definition

±0.08% FS (Typically ±0.05% FS)

Long Term Stability

At standard reference conditions the calibration will not change by more than 0.1% FS/annum (0.05% FS typical).

Operating Temperature Range

- Ambient: -5°F to 175°F (-20°C to 80°C)
- Process media: -20°F to 250°F (-29°C to 121°C)
- Storage: -40°F to 250°F (-40°C to 121°C)

Temperature Effects

For ranges of 5 psi (350 mbar) and above, the output will not deviate from room temperature calibration by more than:

- 0.5% FS over 15°F to 122°F or (-10°C to 50°C) or 1% FS over -5°F to 175°F (-20°C to 80°C)
- Typically 0.3% FS, 15°F to 122°F (-10°C to 50°C)
- 0.7% FS, -5°F to 175°F (-20°C to 80°C)

For ranges below 5 psi (350 mbar) these values will increase pro-rata with calibration span.

PTX 651/671 Specifications

Material Compatibility

- 316L stainless steel/Hastelloy C276
- All Hastelloy C276 (optional)
- All Monel 400 (optional)

Weight

- PTX 651: 1.8 lb (0.82 kg)
- PTX 671: 4 lb (1.82 kg)

Intrinsic Safety

These transmitters are certified for use with barrier systems to CSA and FM Certification Class I, Division 1, Groups A,B,C&D with a T4 temperature code. ATEX certification available on request.

Process Connection

1/2 NPT male

Features

- 1) Glass-filled polyester junction box (PTX 671)
- 2) Aluminium bronze disconnect ring
- 3) All 316 stainless steel welded body
- 4) In-line diode for output current monitoring (PTX 671)
- 5) Gold plated disconnect plug/socket (PTX 671)

Ordering information

Please state the following:

(1) Type number

PTX	Code	Description	Code	Temperature effect	Code	Electrical connection
↓	651		0	-15°F to 122°F (-26°C to 50°C)	5	3/4 NPT female conduit
↓	671		1	-5°F to 175°F (-20°C to 80°C)	7	Junction box
PTX -	-	-	-	-	-	Typical Model Number

Specification otherwise the same as PTX 600 Series data sheet.

GE
Sensing



©2006 GE. All rights reserved.
920-186A

All specifications are subject to change for product improvement without notice.
GE® is a registered trademark of General Electric Co. Other company or product
names mentioned in this document may be trademarks or registered trademarks
of their respective companies, which are not affiliated with GE.

www.gesensing.com