

Features

- National Institute of Standards and Technology (NIST) traceable, field-replaceable sensor
- Full Scale (FS) 0 to 100% RH measurement
- NIST traceable factory calibration
- User selectable RH and temperature outputs
- Robust, proven capacitive sensor technology
- Attractive and rugged packaging
- 2% or 5% RH accuracy
- NIST certification available
- Versatile temperature measurement
- Temperature compensated
- Low cost of ownership
- Two year warranty

Applications

- HVAC/building controls
- Energy Management Systems (EMS)
- Enthalpy control
- Indoor Air Quality (IAQ)
- Clean rooms
- Museums/archives
- Hospitals/labs
- Refrigeration control
- Pharmaceutical
- Swimming pools
- Animal rooms

HumiTrac™

General Eastern Relative Humidity/Temperature Transmitters

HumiTrac is a General Eastern product. General Eastern has joined other GE high-technology sensing businesses under a new name—GE Industrial, Sensing.



GE Sensing

Enhanced Field Serviceability

HumiTrac features a National Institute of Standards and Technology (NIST) traceable, field-replaceable sensor tip module that allows the end user to replace the sensor on-site while maintaining $\pm 2\%$ RH accuracy and NIST traceability. The user simply powers off the unit, installs the new sensor module and powers back the unit. All necessary calibration constants are stored in the memory of the sensor module and uploaded to the transmitter instantly. This virtually eliminates the need for time consuming and costly factory calibration, while reducing downtime during service intervals to near zero.

Unsurpassed Sensor Performance

HumiTrac utilizes a rugged capacitive sensor that provides full-scale 0-100% RH measurement with unsurpassed response times, linearity and stability. Recovery to condensation and chemicals is excellent and an integrated filter, plus conformal-coated module electronics ensure long life. All sensors undergo a ten hour digital calibration, certified against a primary NIST reference standard. Signal conditioned temperature versions maintain specified RH accuracy across the full operating range of -40°F to 140°F (-40°C to 60°C).

Maximum Flexibility

HumiTrac is designed to be highly configurable in the field or in your warehouse. By minimizing the necessary number of configurations, GE reduces distributor inventory costs and provides maximum flexibility to the installer. All versions feature field-selectable outputs (0 to 5V, 0 to 10V, 4 to 20mA) and passive temperature versions incorporate both a 3K and 10K Ω thermistor. Simple adjustment of slide switches is all that is required. Signal-conditioned temperature versions are available scaled from 32°F to 122°F (0°C to 50°C) or -40°F to 140°F (-40°C to 60°C). Custom ranges are available upon request for high volume applications.

HumiTrac is available in humidity accuracies of $\pm 2\%$ or $\pm 5\%$, and offered in wall mount, duct mount and outdoor air configurations

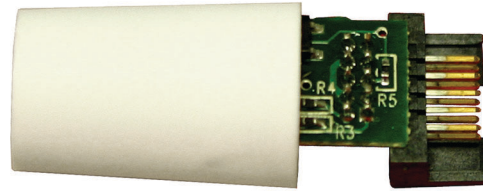

Rugged, Attractive Enclosures

All HumiTrac configurations feature rugged flame retardant, UL-94V ABS plastic. Duct and outdoor air versions provide excellent weather resistance (IP42 rated). Special care has been taken in the design of the wall mount enclosure to provide enhanced airflow, increasing sensor response time and virtually eliminating the potential of "self-heating" by transmitter electronics that can lead to decreased accuracy measurements.

Simple, Fast Installation

All HumiTrac models feature large removable, pluggable terminal blocks, eliminating the need to wire in a confined space and allow the unit to be pre-wired separate from the electronics—an especially attractive feature in unfinished construction, where exposed sensors and electronics could be damaged by moisture, drywall dust and paint. All models incorporate a retaining wire that attaches the cover to the base, allowing the installer to wire the unit without using an extra hand to hold the cover.

Lowest Cost of Ownership

With a two-year warranty*, simplified inventory management, reduced installation times and field-serviceability, HumiTrac sets the standard in reduced cost of ownership and performance-to-price ratio.

**Transmitter only, one year warranty on replaceable sensor.*

HumiTrac Specifications

Environmental Conditions

Operating Range

- -40°F to 140°F (-40°C to 60°C)
- 0% to 99% RH (non-condensing)

Storage Temperature

-67°F to 185°F (-55°C to 85°C)

Humidity

Sensing Element

Capacitive polymer sensor

Accuracy at 71.6°F (22°C)

- ±2% version: ±2% 10 to 90% RH
±5% 0 to 10% & 90-99% RH
- 5% version: ±5% RH @ 0 to 99% RH

**Includes hysteresis, linearity and repeatability*

Long Term Stability

Less than 1% drift per year, typical

Temperature Effect**

$\Delta\%RH = (0.0014 \times \%RH + 0.1325) \times T^{\circ}C - (0.0317 \times \%RH + 3.0876)$

***Not applicable to signal-conditioned temperature units.*

Repeatability

See accuracy statement

Linearity

See accuracy statement

Hysteresis

- < ±1.5% RH (30%RH 1h ->70%RH 1h
->90%RH 1h ->30%RH, Vair = 2m/sec)

Signal Outputs

4 to 20mA, 0 to 5V or 0 to 10V (user selectable)

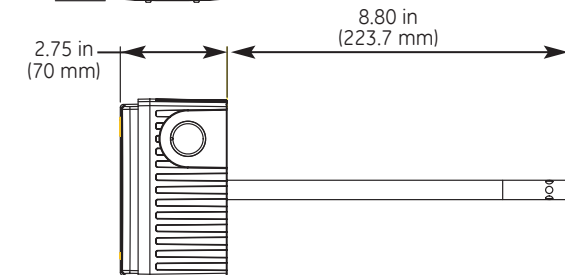
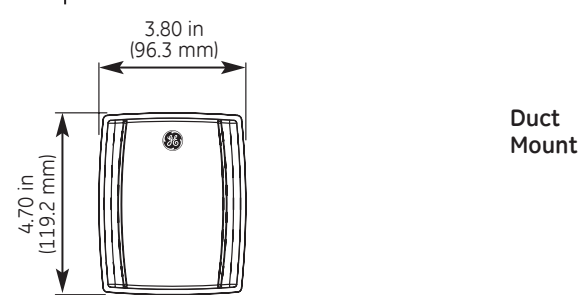
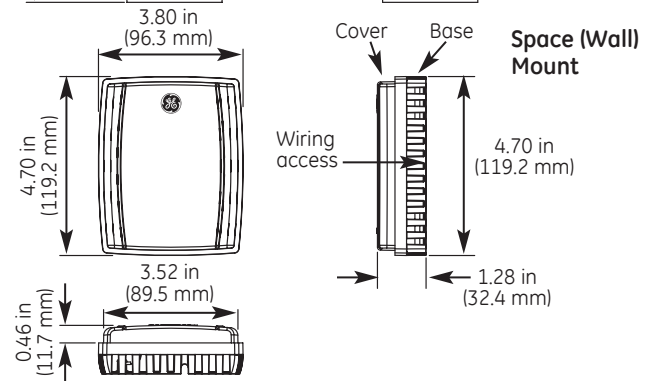
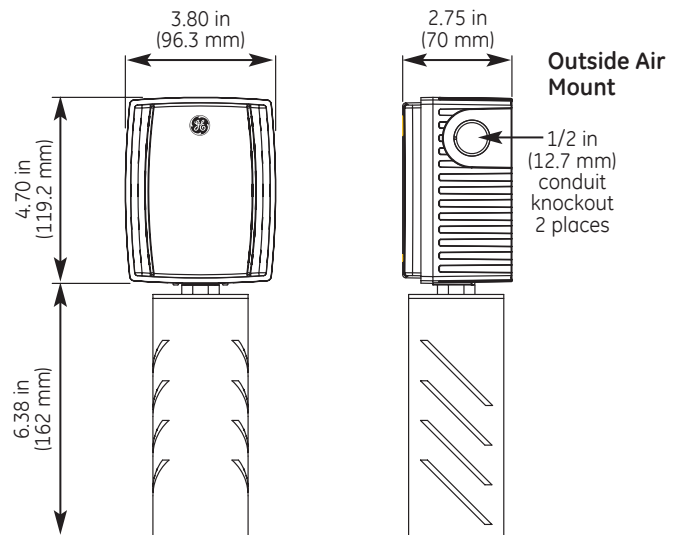

Outside Air Mount

Case: ABS flame retardant IP42 rated

Space (Wall) Mount

Case: ABS flame retardant

Duct Mount

Case: ABS flame retardant IP42 rated

Probe: Stainless steel

HumiTrac Specifications

Temperature-Direct Connection Thermistor

Sensing Element

- 10K Ω thermistor at 77°F (25°C)
- 3K Ω thermistor at 77°F (25°C)

Signal Output

Direct connection, user selectable between 3K or 10K

Accuracy

Refer to DC95F103W (10K) and DC95F302W (3K) from GE

Temperature-Signal Conditioned PRTD

Sensing Element

1000 Ω thin film platinum RTD with signal conditioning

Calibration Accuracy at 71.6°F (22°C)

$\pm 0.5^\circ\text{F}$ ($\pm 0.3^\circ\text{C}$)

Long Term Stability

Less than 0.2°F drift per year

Sensor Interchangeability

$\pm 0.5^\circ\text{F}$ ($\pm 0.3^\circ\text{C}$)

Signal Outputs

4 to 20mA, 0 to 5V or 0 to 10V (user selectable)

Power Requirements

Supply Voltage

12 to 30 VDC

Maximum Load (current output only)

$$\Omega = \frac{\text{Supply Voltage} - 10}{0.02}$$

General

European Compliance

Complies with EMC Directive 89/336/EEC and LVD 73/23/EEC for non-industrial applications

(For EN6100-4-3 and EN61000-4-6 the product meets performance criteria A and , in a limited number of frequencies, performance criteria B per EN31326)

Protection

IP42 rating for Duct Mount and Outside Air Transmitters

Ordering Information

Model	Accuracy		
	5%	2%	2% with NIST Certificate
Space (Wall) Mount			
<i>RH only</i>	P40250121	P40250109	P40250139
<i>RH and 3/10K Ω thermistor</i>	P40250122	P40250110	P40250141
<i>RH and 1000 PRTD 32°F to 122°F (0°C to 50°C)*</i>	P40250123	P40250111	P40250142
<i>RH and 1000 PRTD -40°F to 140°F (-40°C to 60°C)*</i>	P40250125	P40250112	P40250143
Duct Mount			
<i>RH only</i>	P40250129	P40250117	P40250147
<i>RH and 3/10K Ω thermistor</i>	P40250130	P40250118	P40250149
<i>RH and 1000 PRTD 32°F to 122°F (0°C to 50°C)*</i>	P40250131	P40250119	P40250150
<i>RH and 1000 PRTD -40°F to 140°F (-40°C to 60°C)*</i>	P40250133	P40250120	P40250151
Outside Air			
<i>RH only</i>	P40250126	P40250113	P40250144
<i>RH and 3/10K Ω thermistor</i>	P40250127	P40250114	P40250145
<i>RH and 1000 PRTD -40°F to 140°F (-40°C to 60°C)*</i>	P40250128	P40250115	P40250146
Replaceable Sensor Tip (RH Only)	P40250161	P40250162	N/A
Replaceable Sensor Tip (RH and Temp-1000) PRTD	P40250163	P40250165	N/A

*Signal conditioned temperature output corresponding to 4 to 20 mA, 0 to 5V or 0 to 10V (user selectable)



©2004 GE. All rights reserved.
920-138A

All specifications are subject to change for product improvement without notice.
HumiTrac™ is a trademark of GE. GE® is a registered trademark of General Electric Co.

www.gesensing.com