

SES

STAINLESS SINGLE-JET METER INSTRUCTIONS

SeaMetrics

SES STAINLESS SINGLE-JET METER
INSTRUCTIONS

GENERAL INFORMATION

This meter provides accurate, wide range flow metering in an extremely rugged stainless steel package. Single-jet simplicity combined with high quality jewel bearings result in long life and relatively high tolerance for problem fluids. Typical applications are chemical batching, proportional chemical injection, fertilizer injection, proportioning of spray chemicals, and general flow rate monitoring.

The pickup is easily replaced from outside the meter, and is compatible with most of the SeaMetrics indicators and transmitters, as well as most controls and PLC's which accept DC inputs. The standard rotor is PVDF (Kynar) and the shaft is a special nickel-bonded tungsten carbide. The optional ceramic shaft increases resistance to some concentrated chemicals. The standard O-ring is Viton.

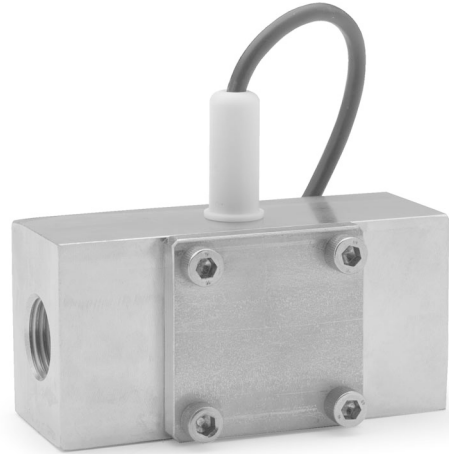

SPECIFICATIONS

CONNECTIONS

- 1/2", 3/4" and 1" female NPT standard
- SAE thread optional

MATERIALS

- | | |
|----------|---|
| Body | • 316 stainless steel |
| Rotor | • PVDF (Kynar) |
| Shaft | • Nickel-bonded tungsten carbide (ceramic optional) |
| Bearings | • Ruby ring and ball |
| O-ring | • Viton |
| Cover | • 316 stainless steel |

MAXIMUM TEMPERATURE

- 200° F (93° C)

MAXIMUM PRESSURE

- 500 psi (35 bar)

ACCURACY

- 1% of reading 10% to 100% of full scale
- 1% of full scale

OUTPUTS

- Current sinking pulse, 6 - 24 Vdc
- Maximum cable run 2,000 ft

FLOW RATES

	GPM	LPM
1/2"	• 0.1 - 10	0.38 - 38
3/4"	• 0.2 - 15	0.75 - 57
1"	• .5 - 25	1.9 - 95

INSTALLATION

Piping Requirements. Standard fittings are female NPT. Straight pipe of at least five diameters upstream of the meter is recommended. Vertical, horizontal, or inverted (cover down) installations are all acceptable.

REPAIR

Rotor Replacement. There is only one moving part to this meter. The bearings are made of ruby, which rarely wears out, and will not need replacement unless they have been physically damaged by severe shock. The shaft is integrally molded into the rotor, and shaft and rotor are replaced as one part. To replace the rotor, remove all pressure from the meter. Then remove the four screws which hold the cover in place. Lift the cover and plastic bearing holder, then remove the rotor.



K-FACTOR
K-FACTOR ON
MODEL/SERIAL
LABEL ON BACK

ELECTRICAL CONNECTIONS

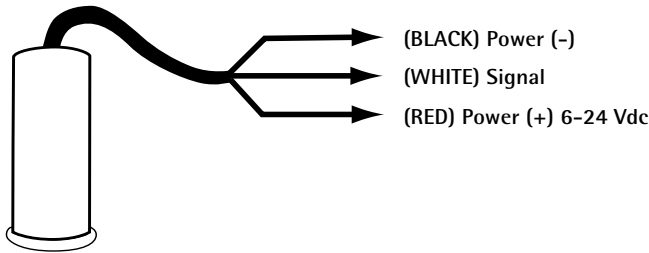

SES SENSOR CONNECTION



Warning: This meter has low-friction bearings. **DO NOT, AT ANY TIME,** test operation of the meter with compressed air! Doing so will subject it to rotational speeds many times those for which it was designed, and will certainly damage the rotor, shaft, and/or bearings.

There are three conductors to the sensor, two for positive and negative power and one for the signal. See the diagram below for color coding. When replacing the rotor, be sure that the ends of the shaft are in both bearings before tightening the cover. The rotor can be easily dropped into the bottom bearing. Starting the shaft into the upper bearing requires a bit of care. It is easier if the rotor is spinning, which can be done by lightly blowing into a port. When the upper bearing holder drops into place, hold it down and check for free spinning before replacing the cover. Replace the cover, insert the four cap screws and tighten. Replace the O-ring in its seat before replacing the rotor.

SENSOR REPLACEMENT

The sensor ordinarily does not need replacement unless it is electrically damaged. If replacement is necessary, unthread the sensor by hand. Thread the replacement sensor in and tighten by hand.

FIELD REPLACEMENT OF SENSOR

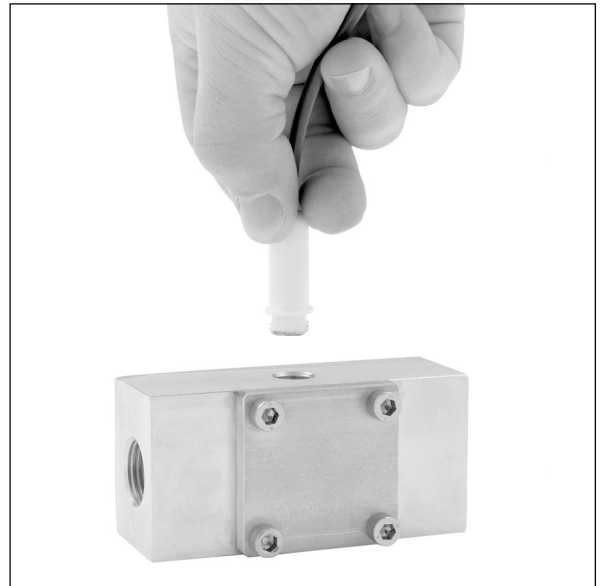

CONNECTING TO NON-SEAMETRICS CONTROL DEVICES

It is often desirable to connect an S-Series flow sensor to a PLC or industrial computer board, and the sensors are well suited for this. Typically it can be connected directly, or with a single resistor added. The S-Series pickup sensors are GMR devices which need 5-24 Volts DC and 2 mA current, and they are current sinking (NPN).

These sensors can connect directly to a PLC or computer board if:

1. The sensor power on the PLC is 5 - 24 VDC (24 VDC is typical.)
2. The sensor power supply can provide at least 2 mA (100 mA is typical.)
3. The sensor input on the PLC can accept a current sinking device.

See Figure 1 for connections.

Input Designed for Current Sinking (NPN) Devices

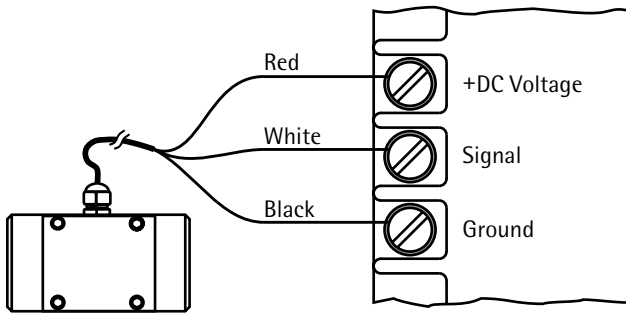

NPN Device

Figure 1

If the PLC input only accepts current sourcing devices, a pull-up resistor must be added. Connection of this resistor is shown in Figure 2. Typically, on a 24 VDC input a 2.2 K Ohm resistor will be effective.

Since the three-wire pickup sensors are solid state, they do not exhibit switch bounce and can be used at relatively high frequencies.

If the PLC is equipped with a 4-20 mA analog input module, it is necessary to order the flow sensor with some form of 4-20 mA transmitter. Two options are the A055 blind transmitter and FT420 indicating transmitter. Follow the connection diagrams for these products to connect to the analog input.

Input Designed for Current Sourcing (PNP) Devices

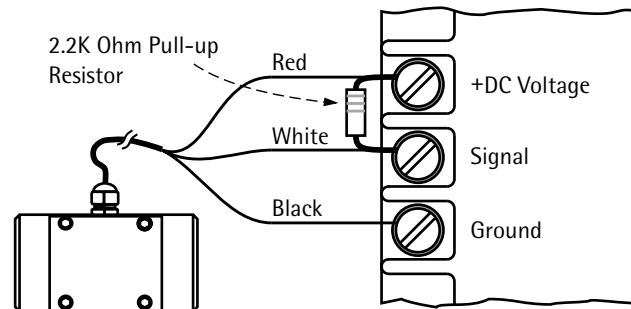

NPN Device

Figure 2

SES STAINLESS SINGLE-JET METER

Instructions

DIMENSIONS

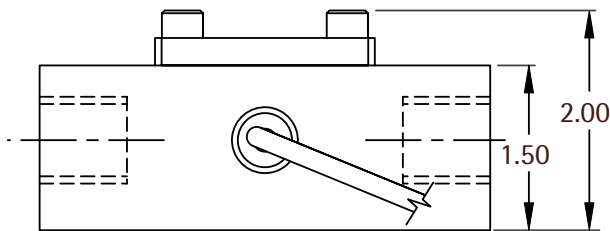
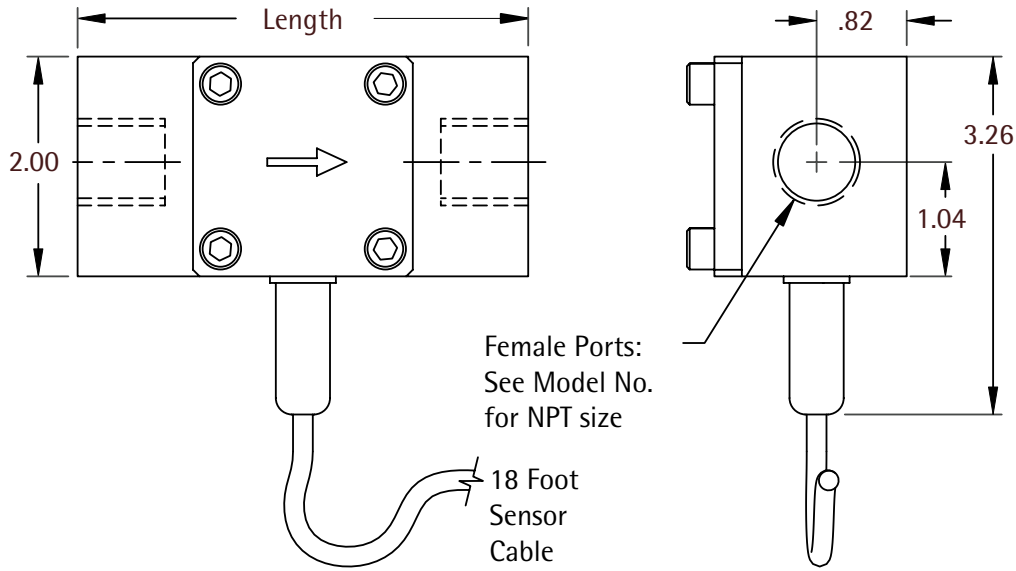

Size	Length
1/2 Inch	4.10
3/4 Inch	4.10
1 Inch	5.00

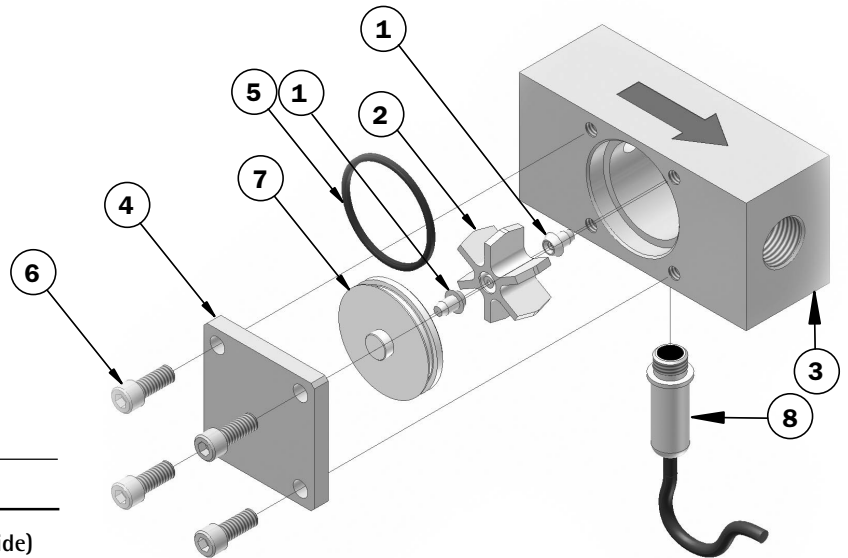

SES PARTS LISTING

1. Bearing Assembly	25150 (2 Required)
2. Rotor	11129 (Shaft Kynar/Carbide)
3. Body	30535 (1/2") 30536 (3/4")
4. Cover	30533 (Carbide)
5. O-Ring	16455 (Viton)
6. Screw	25370
7. Bearing Plate	30532
8. Sensor	25310

SeaMetrics

19026 72ND AVE. SOUTH, KENT, WA 98032 USA
(P) 253.872.0284 (F) 253.872.0285
WWW.SEAMETRICS.COM 1.800.975.8153