

Applications

An oxygen transmitter for use in:

- Heat treating and bright annealing
- Process monitoring of gaseous monomers
- Pure gaseous hydrocarbon streams
- Inert welding gases
- Glove box leak detection
- Ambient air monitor

Features

- Intrinsically safe
- Two-wire, loop-powered 4 to 20 mA transmitter
- Proven galvanic fuel cell O₂ sensor technology
- Programmable ranges for ppm and percent oxygen
- Microprocessor-based, all-digital technology for reliable operation
- Continuous monitoring
- Low maintenance
- Economical and compact

O2X1

Panametrics Oxygen Transmitter

O2X1 is a Panametrics product. Panametrics has joined other GE high-technology sensing businesses under a new name—GE Industrial, Sensing.



GE Sensing

Panometrics Oxygen Transmitter

The O2X1 is a highly reliable and cost-effective two-wire, loop-powered transmitter with a linearized 4 to 20 mA output. It measures oxygen in four ppm ranges (10; 100; 1,000 and 10,000 ppm) and three percentage ranges (1, 10, and 25%). All ranges are user-programmable. This compact transmitter uses proven sensor technology to accurately measure O₂ in a variety of gases, even in hazardous environments.

Proven Sensor Technology

The O2X1's oxygen sensor is an advanced galvanic fuel cell that provides superior performance, accuracy, stability and long life. The cell's innovative design eliminates the potential for negative signal output, reduces sources of contamination and eliminates electrolyte leakage.

The cell is unaffected by other background gases or hydrocarbons and is compatible with acid gases (OX-2 and OX-4 cells). Recovery from air at low ppm levels takes just a few minutes. Because the cell is self-contained, little maintenance is required. There is no electrolyte to change or electrodes to clean.

Intrinsically Safe

When equipped with the optional MTL706 barriers, the O2X1 can be mounted in a hazardous (classified) location as defined by the National Electrical Code (NEC). The O2X1 316 stainless steel package is FM approved as intrinsically safe for use in Class I, II, III; Division 1; Groups A,B,C,D,E, F&G hazardous (indoor/outdoor) Type 4X locations, and is certified by BASEEFA II 1 G EEx ia IIC T4 (Tamb = -20°C to +60°C).

Control at the Tip of a Finger

The rugged O2X1 is controlled by a microprocessor that enables the user to select the range, trim outputs and perform calibration. Programming is easily done using

the three-button keypad and the three light-emitting diodes (LEDs). These switches allow complete functionality in hazardous areas when equipped with an MTL706 barrier.

Installation Flexibility

The compact O2X1, with its built-in microprocessor, is designed to fit easily into any installation site. The O2X1 can be installed right at the sampling point, whereas other transmitters must be rack or panel mounted.

Sample Systems

In addition to standard features and options, GE offers a full line of sample handling systems for a variety of applications. If needed, GE can design and build a sample conditioning system to meet unique application requirements. Please contact GE for details.

Oxygen Sensor Interference Gases

Gas	OX-1, ppm	OX-2, ppm	OX-3, %		OX-4%	
	Cont.	Cont.	Cont.	Int. (1)	Cont.	Int.
H ₂ S	<5ppm	<10ppm	0.0005%	0.01%	0.001%	0.1%
SO ₃	<10 ppm	<10 ppm	0.01%	0.1%	0.01%	0.1%
SO ₂	<10 ppm	(3)	0.01%	0.1%	(3)	(3)
HCl	<1000 ppm	(3)	0.1%	1.0%	(3)	(3)
HCN	<1000 ppm	(3)	0.1%	1.0%	(3)	(3)
CO ₂	<1000 ppm	(3)	0.1%	20%	(3)	(3)
NO ₂	(2)	(2)	(2)	(2)	(2)	(2)
CL ₂	(2)	(2)	(2)	(2)	(2)	(2)

Cont. = Continuous, Int. = Intermittent

(1) Recommended maximum exposure 30 minutes followed by flushing with ambient air for equal period

(2) Minimal effect on sensor performance, but produces signal interference of 1:2 ratio

(3) Minimal effect on sensor performance

O2X1 Specifications

Intrinsically Safe (IS) Installation

Intrinsically safe installations require an MTL706 zener barrier, one IS cable and one non-IS cable.

Power Requirements

24 to 28 VDC at 50 mA

Cable

- OCI-*F-T5 in hazardous area: Two-conductor, twisted pair with connector; 22 AWG; 1100 ft (335 m) maximum cable length
- OCG-*F-0 in non-hazardous (safe) area: Three-conductor; 22 AWG; 4000 ft (1219 m) maximum cable length

Output

Total load must equal $250 \Omega \pm 5\%$

Non-Hazardous (Safe) Installation

No zener barrier is used.

Process Wetted Materials

- SS process unit: 316 stainless steel, Viton® O-ring and polytetrafluoroethylene
- Delrin® process unit: Delrin, Viton O-ring and polytetrafluoroethylene
- Ambient air monitoring unit: Delrin, Viton O-ring and polytetrafluoroethylene

Power Requirements

9 to 28 VDC loop powered, 0.6 W max

Cable

OCG-*F-T5: 2 conductor, twisted pair with connector; 22 AWG; 0.04 Ω /ft; 4000 ft (1219 m) maximum cable length

Output

Max. load (Ω) = $[40 \Omega \times (\text{PSV} - 8)] - \text{RC}$ where:
PSV = power supply voltage in VDC, and
RC = cable resistance (22 AWG cable has 0.04 Ω /ft)

Example:

Given a 24 VDC power supply and a 1000 ft (305 m) cable (22 AWG, 0.04 Ω /ft),

$$\text{RC} = 1000 \text{ ft} \times 0.04 \text{ } \Omega/\text{ft} = 40 \text{ } \Omega$$

$$\begin{aligned} \text{Max. load} &= [40 \times (24 - 8)] - 40 \\ &= [40 \times 16] - 40 \\ &= 600 \text{ } \Omega \end{aligned}$$

Field Programmable

Measurement Ranges

- Ppm sensors:
 - 0 to 10 ppmv O₂ (316 stainless steel package)
 - 0 to 100 ppmv O₂
 - 0 to 1000 ppmv O₂
 - 0 to 10,000 ppmv O₂
- Percent sensors:
 - 0% to 1% O₂
 - 0% to 10% O₂
 - 0% to 25% O₂

Accuracy

- $\pm 1\%$ of span at calibration point
- $\pm 2\%$ of span at the calibration point for the 0 to 10 ppmv range (316 stainless steel package only)

Repeatability

- $\pm 1\%$ of span
- $\pm 2\%$ of span for the 0 to 10 ppmv range (316 stainless steel package only)

Resolution

$\pm 0.1\%$ of span

Linearity

$\pm 2\%$ of span

Operating Temperature

32°F to 113°F (0°C to 45°C)

Ambient Temperature Effect

$\pm 3\%$ of reading over operating temperature range

Sample Pressure

Vented to atmosphere during operation and calibration

Atmospheric Pressure Effect

$\pm 0.13\%$ of reading per mmHg (directly proportional to absolute pressure). During calibration, pressure and flow must be kept constant.

Process Connection

- 316 stainless steel and Delrin process units:
 - 1/8 in NPT inlet and outlet
- Ambient air monitoring unit: None

Sample Flow Rate

1.0 SCFH (500 cc/min) recommended for process units
Electrical Classification/Certification

- Weatherproof, 316 stainless steel and Delrin process packages only: Type 4X/IP66
- Intrinsically safe, 316 stainless steel package only:
Class I, II, III; Division 1; Group A,B,C,D,E,F&G;
FM/CSA
⊕ II 1 G EEx ia IIC T4
(Tamb = -20°C to +60°C);
BAS01ATEX1094X
316 stainless steel ATEX compliance with EN50104
from 32°F to 104°F (0°C to 40°C)

European Compliance

Complies with EMC Directive 89/336/EEC

Order Information

Record selected option in blank indicated at bottom of form.

O2X1 Oxygen Transmitter

Sensor

- 0 None
- 1 Standard ppm
- 2 Acid ppm
- 3 Standard %
- 4 Acid %

Package

- 0 316 stainless steel process FM/CSA
- 1 Delrin process
- 2 Delrin ambient air monitoring
- 3 316 stainless steel process ATEX
- 9 316 stainless steel general purpose

O2X1 - _ _ Use this number to order product

OX Spare Oxygen Sensor

Sensor

- 1 Standard ppm
- 2 Acid ppm
- 3 Standard %
- 4 Acid %

OX - _ Use this number to order product

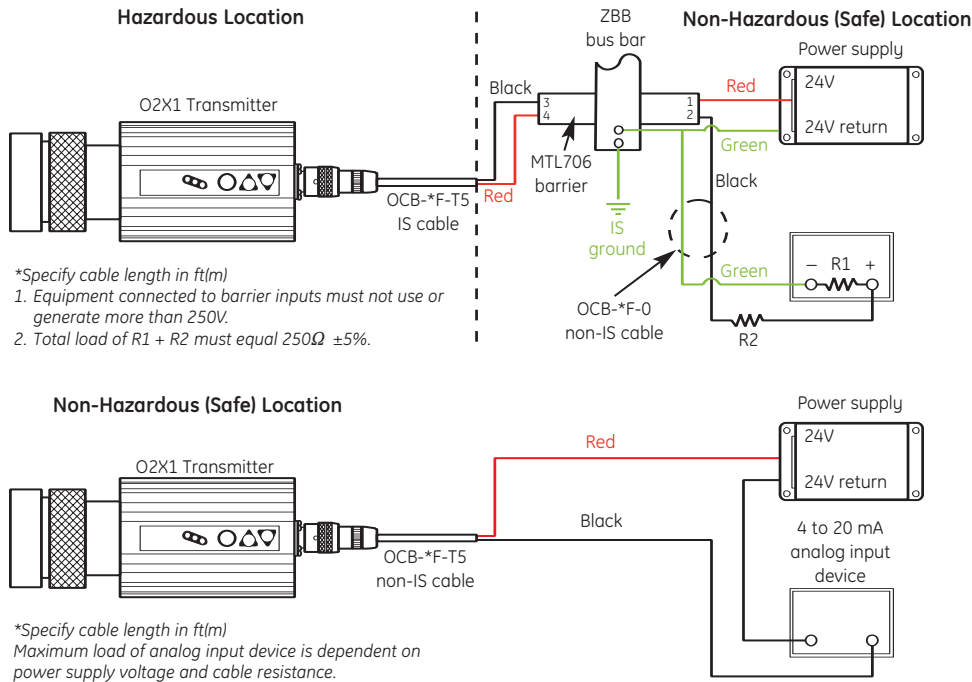

O2X1 intrinsically safe installation (top) and non-hazardous (safe) installation (bottom).



©2005 GE. All rights reserved.
920-040C

All specifications are subject to change for product improvement without notice. GE® is a registered trademark of General Electric Co. Other company or product names mentioned in this document may be trademarks or registered trademarks of their respective companies, which are not affiliated with GE.

